

10^o RALLY MAR Y SIERRAS PREMIO CORONACIÓN AYACUCHO



LIBRO DE RUTA

bellido



Rally de
Ayacucho
2023



Pag
1

rallymarysierras.com.ar

REGLAMENTO PARTICULAR

1 - Programa

Jueves 30 de Noviembre de 2023

20:00 hs. Cierre de Inscripciones

Viernes 1 de Diciembre de 2023

09:30 a 14:30 hs. Verificación Administrativa: Secretaría de la Pruba C.A.I.

09:30 a 16:00 hs. Verificación Técnica: Parque de Asistencia C.A.I.

14:00 a 17:00 hs. Shakedown - C.A.I.

18:00 a 19:00 hs. Parque Previo Largada Promocional - Saenz Peña y Alem

19:30 hs. Reunion de Pilotos: Casa de la Cultura, H.Yrigoyen 941

20:00 hs. Largada Promocional: Municipalidad de Ayacucho, Alem 1078

Sábado 2 de Diciembre de 2023

08:30 hs. Largada DIA 1 - Sección 1 (1^o Auto)

CH0 - Pqe.Asistencia
9 Pruebas Especiales (111,75 Km.)

17:42 hs. Fin DIA 1 - Sección 2 (1^o Auto)

CH9C - Parque Cerrado (Ingreso)

Domingo 3 de Diciembre de 2023

08:00 hs. Largada DIA 2 - Sección 4 (1^o Auto)

CH9D - Parque Cerrado (Salida)
4 Pruebas Especiales (65,84 Km.)

12:33 hs. Fin DIA 2 - Sección 5 (1^o Auto)

CH15A - Parque Cerrado (Ingreso)

14:30 hs. Verificación Técnica Final: Vialidad Municipal, Ruta 50 km. 73.5
Podio Final (horario a confirmar)

2 - Organización

2.1 Definición

Este Rally está organizado por el AUTO MOTO CLUB AYACUCHO

La denominación de la Prueba es: RALLY CIUDAD DE AYACUCHO GRAN PREMIO CORONACION 2023 y está programado para los días 1 al 3 de Diciembre de 2023.

2.2 Generalidades

Esta prueba será disputada conforme al CDA de la FIA y sus anexos, al RDA y sus anexos, a las Prescripciones Generales de Rally y sus anexos, al Reglamento Zonal de la Federación Mar y Sierras y sus anexos, al Presente Reglamento Particular de la Prueba (RPP) y sus anexos, al Código de Tránsito de la República Argentina, a las Leyes y Normas de tránsito provinciales y municipales por donde atravesare el itinerario del Rally y a las indicaciones de las personas encargadas de la seguridad.



3 - Autoridades de la Prueba

Director de la Prueba: Sr. Alejandro Flores

Director Adjunto: a designar

Comisario Deportivo: Sr. Daniel Jordan

Comisario Técnico: Sr. Fabian Alvarez

Responsable de Seguridad: a designar

Responsable de Sanidad: Hospital Municipal

Relaciones con los Concurrentes: Sr. Alejandro Flores

Responsable de Cronometraje y Clasificaciones: Sr. Hugo Gavilán

Libro de Rutas: A.CRO.DEP.

Oficiales Deportivos: A.CRO.DEP.

4 - Elegibilidad

Esta Competencia es válida por la 9ª Fecha del Campeonato de Rally Mar y Sierras de Pilotos y Navegantes, y está clasificada como de Graduación 2 a los efectos del otorgamiento de puntajes.

5 - Fiscalización

Esta Competencia será fiscalizada por la Federación Mar y Sierras, quienes designarán las autoridades correspondientes.

6 - Recorrido

Este Rally consta de 15 (quince) Pruebas Especiales. Las Etapas, Secciones, Sectores, Controles Horarios, Parques de Servicio, Reagrupamientos, Parques Cerrados, tiempos ideales otorgados, tiempos máximos y recorridos obligatorios están descritos en el Libro de Rutas, y en los Carnet de Control.

Los tramos comprendidos entre Controles Horarios se denominan Sectores y dentro de éstos podrá o no haber Pruebas Especiales.

ES OBLIGATORIO RESPETAR EL RECORRIDO REALIZADO CON MAQUINARIA VIAL, El abandono intencional del recorrido demarcado por la maquinarias vial, podrá ser penalizado

7 - Chicanas

Cuando se tomaron las medidas para el Libro de Rutas las chicanas solo estaban proyectadas, por tal motivo puede haber alguna diferencia en metros en su ubicación final.

8 - Derechos de Inscripción y Seguro Médico

Los Derechos de Inscripción han sido fijados en \$ _____ para todas las clases, mientras que el Seguro Médico Obligatorio será provisto por la Asociación Argentina de Volantes con un costo de \$ _____, más Seguro de Accidente y Vida \$ _____, para la tripulación y 2 mecánicos por auto.



9 - Reconocimientos

El reconocimiento de caminos será libre en horario y pasadas, respetando las Leyes de Tránsito. Se aconseja tomar la máxima precaución, ya que el reconocimiento se realiza sobre caminos abiertos a la libre circulación y pueden encontrarse con vehículos particulares circulando en sentido inverso al tramo de Rally.

A los efectos de lo mencionado se advierte que los reconocimientos son solo a efectos de levantar las notas de la Hoja de Ruta, y NO pruebas de velocidad con vehículos de reconocimiento.

Es por ello que se controlará la velocidad con pistola y en casos de incumplimiento se sancionará a quienes no respeten las velocidades permitidas.

10 - Parque de Presentación y Rampa de Largada

La presencia de todos los Autos, Pilotos y Navegantes que hubieran completado la Verificación Administrativa es OBLIGATORIA, salvo aquellos casos que las autoridades consideren de fuerza mayor.

11 - Largada con Semaforo

Las largadas de las Pruebas Especiales se realizarán utilizando un dispositivo electrónico de cuenta regresiva, (Semaforo), La cuenta regresiva de descontará segundo a segundo y será claramente visible por la tripulación desde su posición de salida.

Una Fotocelula ubicada a 50 cms. de la línea de inicio será utilizada para detectar falsas largadas.

Ante una eventual rotura del Semaforo el Oficial de Largada procederá a dar indicaciones verbales y mediante señas para la partida de cada auto en su hora exacta. En todo momento las tripulaciones deberán respetar las indicaciones de los Oficiales Deportivos.

Si un competidor parte antes de su hora establecida, debe continuar su marcha sin detenerse y será pasible a las penalizaciones que establecen el Reglamento General del Rally Mar y Sierras (Art.28.6).

12 - Re Largada en la Etapa 2 luego del Abandono en la Etapa 1 (Reenganche)

De acuerdo a lo establecido en el Art. 36.4 del Reglamento General del Rally Mar y Sierras, aquellas autos que hayan abandonado en la Etapa 1, (por motivos mecánicos o excesos en tiempos), serán clasificados e incluidos en el Orden de Largada de la Etapa 2, siguiendo los lineamientos del artículo citado (Rally 2).

Los Autos que relarguen deberán ingresar al Parque Cerrado antes que ingrese el último Auto al final de la Etapa 1, o media antes de la salida del primer auto en la Etapa 2.

Si una Tripulación no puede o no desea largar la Etapa 2 deberá informar a la Dirección de la Prueba, de ser posible antes de la publicación del Orden de Largada de la Etapa 2.

13 - Casos no Previstos

La Dirección de la Prueba, con el acuerdo de los Comisarios Deportivos, está facultada para tomar las decisiones necesarias para solucionar casos no previstos, como así también decisiones que mejoren el desarrollo de este Rally.

Cualquier resolución será comunicada a los participantes de la forma más directa posible.



RALLY DE AYACUCHO 2023 Cronograma Dia 1 - Secciones 1, 2 y 3

CH/PE	Lugar	Dist. PE	Dist. Enlaces	Dist. Totales	Tiempo Otor.	1º Auto
INICIO - Sección 1						
Sabado 2 de Diciembre 2023						
CH0	Pque. Asistencia Sal.					08:30
RZ1	Reabastecimiento 1		1,50			
CH1			45,58	47,08	00:45	09:15
PE1	El Chinchulin (1)	12,45				09:18
CH2			18,68	31,13	00:30	09:48
PE2	Loma de Ceveiro (1)	13,80				09:51
CH3			9,80	23,60	00:25	10:16
PE3	La Cava - C.A.I. (1)	10,50				10:19
CH3A	Pque. Asistencia Ing. (Flexi)		1,30	11,80	00:15	10:34
	Flexi Service			Max:	00:15	
CH3B	Pque. Asistencia Ing.					10:34
	ASISTENCIA 1				00:30	
CH3C	Pque. Asistencia Sal. / Reagrupamiento Ing.					11:04
	REAGRUPAMIENTO 1			Max:	00:30	
	Subtotal Sección 1	36,75	76,86	113,61		
INICIO - Sección 2						
CH3D	Reagrupamiento Sal.					11:34
RZ2	Reabastecimiento 2		1,50			
CH4			45,58	47,08	00:45	12:19
PE4	El Chinchulin (2)	12,45				12:22
CH5			18,68	31,13	00:30	12:52
PE5	Loma de Ceveiro (2)	13,80				12:55
CH6			9,80	23,60	00:25	13:20
PE6	La Cava - C.A.I. (2)	10,50				13:23
CH6A	Pque. Asistencia Ing. (Flexi)		1,30	11,80	00:15	13:38
	Flexi Service			Max:	00:15	
CH6B	Pque. Asistencia Ing.					13:38
	ASISTENCIA 2				00:30	
CH6C	Pque. Asistencia Sal. / Pque. Cerrado Ing.					14:08
	REAGRUPAMIENTO 2			Max:	00:30	
	Subtotal Sección 2	36,75	76,86	113,61		
INICIO - Sección 3						
CH6D	Reagrupamiento Sal.					14:38
RZ3	Reabastecimiento 3		1,50			
CH7			45,58	47,08	00:45	15:23
PE7	El Chinchulin (3)	12,45				15:26
CH8			18,68	31,13	00:30	15:56
PE8	Loma de Ceveiro (3)	13,80				15:59
CH9			9,80	23,60	00:25	16:24
PE9	La Cava - C.A.I. (3)	10,50				16:27
CH9A	Pque. Asistencia Ing. (Flexi)		1,30	11,80	00:15	16:42
	Flexi Service			Max:	00:45	
CH9B	Pque. Asistencia Ing.					16:42
	ASISTENCIA 3				01:00	
CH9C	Pque. Asistencia Sal. / Pque. Cerrado Ing.					17:42
	CH9C No penaliza adelanto					
	Subtotal Sección 2	36,75	76,86	113,61		
	Total Etapa 1	110,25	230,58	340,83		



RALLY DE AYACUCHO 2023 Cronograma Dia 2 - Secciones 4 y 5

CH/PE	Lugar	Dist. PE	Dist. Enlaces	Dist. Totales	Tiempo Otor.	1º Auto
INICIO - Sección 4						
Domingo 3 de Diciembre 2023						
CH9D	Pque. Cerrado Sal. / Pque. Asistencia Ing.					08:00
	ASISTENCIA 4				00:25	
CH9E	Pque. Asistencia Sal.					08:25
RZ4	Reabastecimiento 4		1,10			
CH10			23,16	24,26	00:30	08:55
PE10	Loma de Ceveiro (4)	13,80				08:58
CH11			4,45	18,25	00:20	09:18
PE11	Chacra Municipal (1)	8,12				09:21
CH12			6,90	15,02	00:20	09:41
PE12	La Cava - C.A.I. (4)	10,50				09:44
CH12A	Pque. Asistencia Ing. (Flexi)		1,30	11,80	00:15	09:59
	Flexi Service			Max:	00:15	
CH12B	Pque. Asistencia Ing.					09:59
	ASISTENCIA 5				00:30	
CH12C	Pque. Asistencia Sal. / Reagrupamiento Ing.					10:29
	REAGRUPAMIENTO 3			Max:	00:30	
	Subtotal Sección 4	32,42	36,91	69,33		
INICIO - Sección 5						
CH12D	Reagrupamiento Sal.					10:59
RZ5	Reabastecimiento 5		1,10			
CH13			23,16	24,26	00:30	11:29
PE13	Loma de Ceveiro (5)	13,80				11:32
CH14			4,45	18,25	00:20	11:52
PE14	Chacra Municipal (2)	8,12				11:55
CH15			6,90	15,02	00:20	12:15
PE15	La Cava - C.A.I. (5)	10,50				12:18
CH15A	Pque. Cerrado Final		1,30	11,80	00:15	12:33
	CH15A No penaliza adelanto					
	Subtotal Sección 5	32,42	36,91	69,33		
	Total Etapa 2	64,84	73,82	138,66		
	TOTAL DEL RALLY	175,09	304,40	479,49		

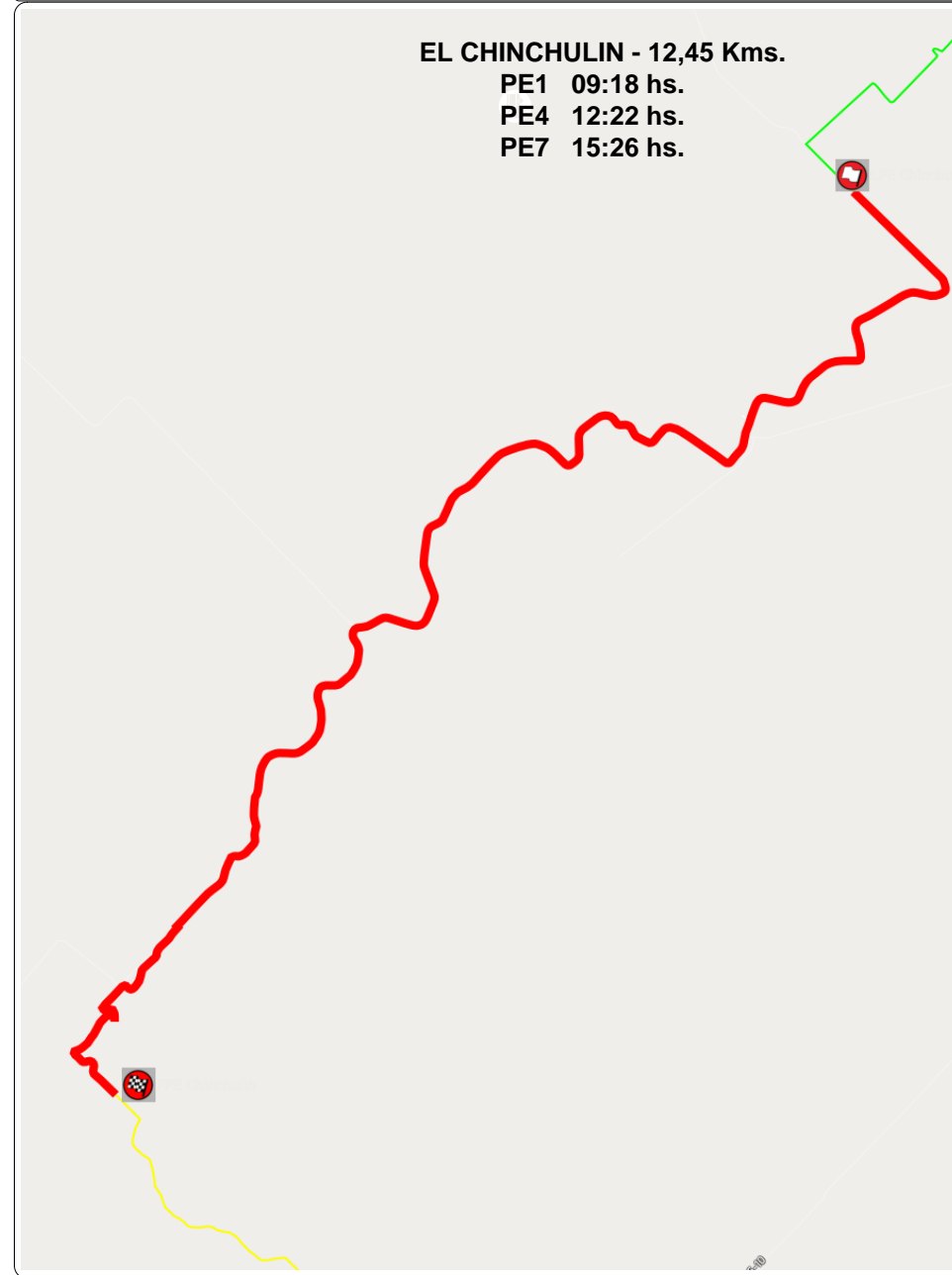
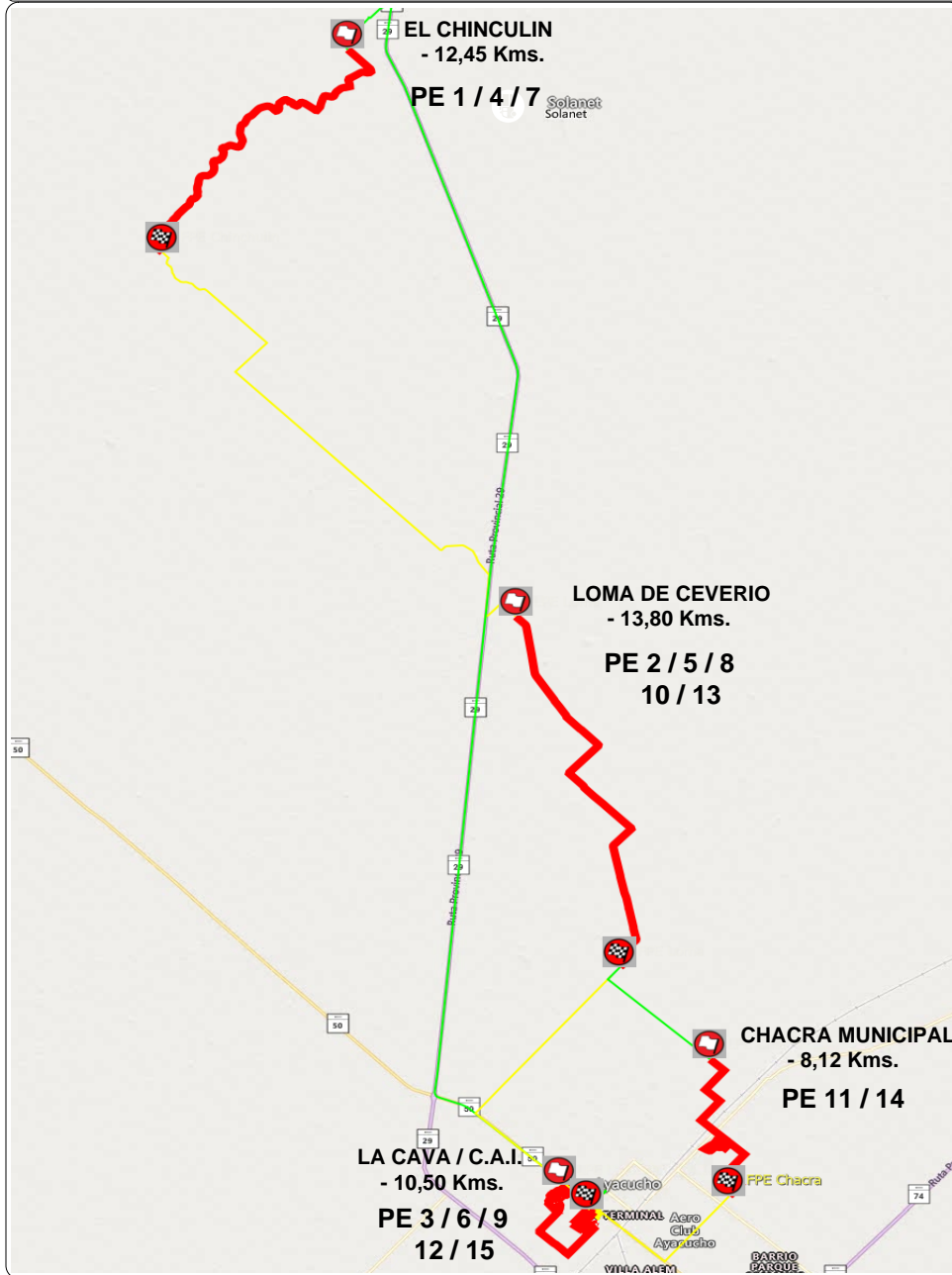



LOMA DE CEVERIO - 13,80 Kms.

PE2 09:51 hs.
PE5 12:55 hs.
PE8 15:59 hs.

PE10 08:58 hs.
PE13 11:32 hs.



CHACRA MUNICIPAL - 8,12 Kms.

PE11 09:21 hs.
PE14 11:55 hs.

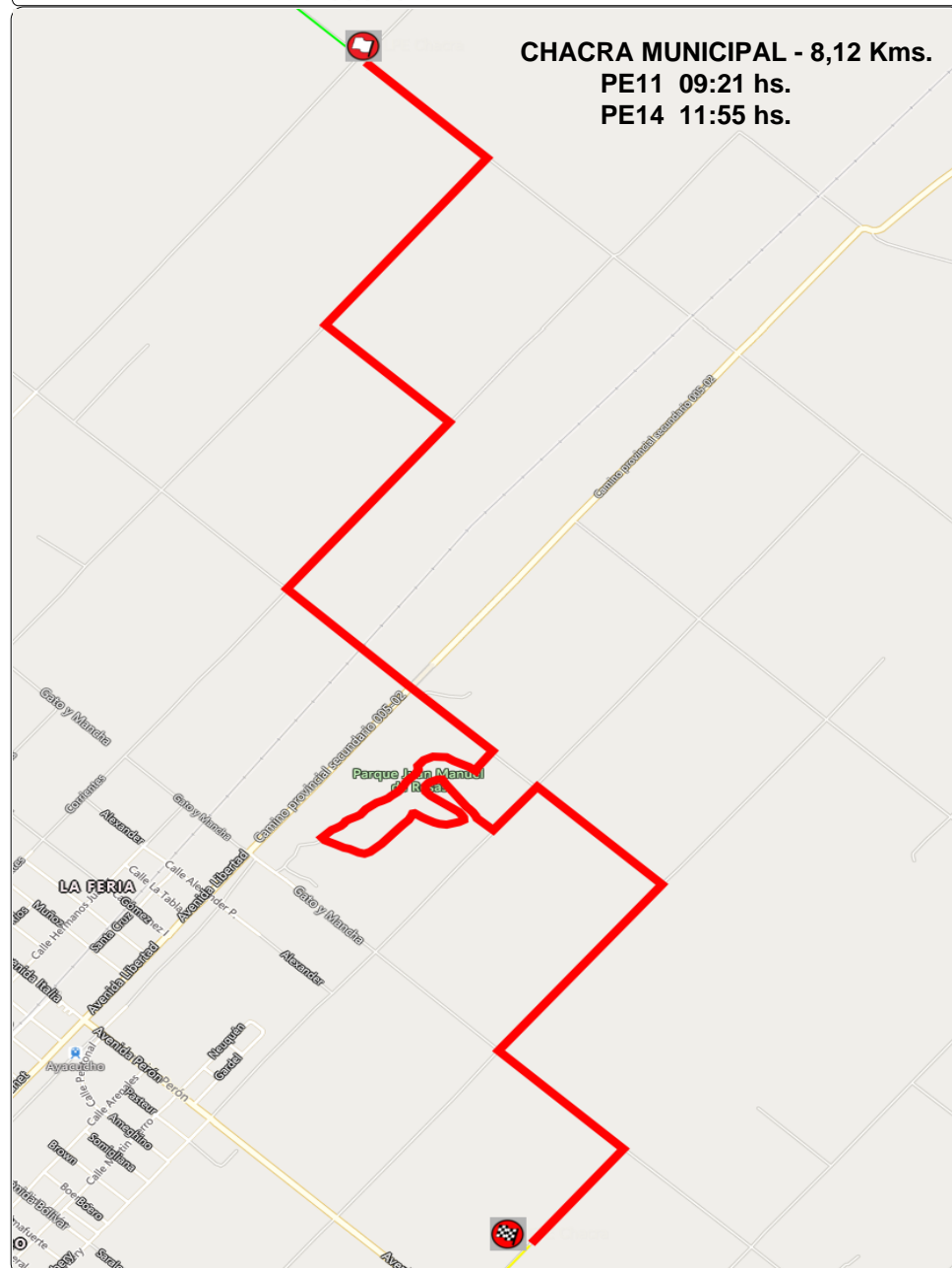



Ubicaciones GPS

Pque. Asistencia - Ingreso

S 37°09.744
O 58°29.903

Pque. Asistencia - Salida

S 37°09.832
O 58°29.859

PE EL CHINCHULIN

Largada

S 36°49.255
O 58°34.756

Llegada

S 36°52.687
O 58°38.533

Stop

S 36°52.753
O 58°38.451

PE LOMA DE CEVERIO

Largada

S 36°59.215
O 58°31.487

Llegada

S 37°05.362
O 58°29.459

Stop

S 37°05.577
O 58°29.695

PE LA CAVA / C.A.I.

Largada

S 37°09.187
O 58°30.630

Llegada

S 37°09.716
O 58°30.226

Stop

S 37°09.562
O 58°30.053

PE CHACRA MUNICIPAL

Largada

S 37°06.978
O 58°27.709

Llegada

S 37°09.368
O 58°27.331

Stop

S 37°09.516
O 58°27.490

PQUE. ASISTENCIA SALIDA		Dist.Sector	Etapa:	Pag 12
LARGADA PROMOCIONAL		1,70 km	Sección:	
Prueba Especial	Dist. P.E.	Promedio	Tiempo Otorgado	
	km	km/h		

distancia		direccion	informacion	distancia regresiva
total	parcial			
0.00	0.00	1 	Salida Asistencia S 37°09.832 O 58°29.859	1.70
0.28	0.28	2 	por Saenz Peña	1.42
1.45	1.17	3 	por Alem Ingresa a Parque previo Largada Promocional	0.25
1.70	0.25	4 	Rampa de Largada S 37°09.174 O 58°29.356	0.00

PQUE. ASISTENCIA SALIDA		Dist.Sector	Etapa:	Pag 13
SHAKEDOWN		km	Sección:	
Prueba Especial	Dist. P.E.	Promedio	Tiempo Otorgado	
	km	km/h		

distancia		direccion	informacion	distancia regresiva
total	parcial			
0.00	0.00	1 	 Shakedown Predio C.A.I. atras de Pque.Asistencia S 37°09.894 O 58°29.941	3.56

Comprendido en la PE La Cava / C.A.I.

desde el final de la Figura 32 Pagina 31

hasta 300 mts. mas de la Figura 57 Pagina 35

Extension 3.56 Kms.

distancia		direccion	informacion	distancia regresiva
total	parcial			
3.56	0.00	1 	 Shakedown S 37°09.716 O 58°30.176	0.00

CH 0 - PQUE. ASISTENCIA SALIDA	Dist.Sector 47,08 km	Etapa: 1	Pag 14
CH 1 - EL CHINCHULIN		Sección: 1	
Prueba Especial	Dist. P.E. km	Promedio 62,77 km/h	Tiempo Otorgado 0:45

distancia		direccion	informacion	distancia regresiva
total	parcial			
0.00	0.00	1 	CH 0 - Pque. Asistencia Sal. S 37°09.832 O 58°29.859	47.08
0.28	0.28	2 	toma Ruta 50	46.80
0.59	0.31	3 		46.49
0.81	0.22	4 	por Avenida Miguens	46.27
1.44	0.63	5 	Reabastecimiento 	45.64
1.50	0.06	6 	por Avenida Miguens	45.58

CH 0 - PQUE. ASISTENCIA SALIDA	Dist.Sector 47,08 km	Etapa: 1	Pag 15
CH 1 - EL CHINCHULIN		Sección: 1	
Prueba Especial	Dist. P.E. km	Promedio 62,77 km/h	Tiempo Otorgado 0:45

distancia		direccion	informacion	distancia regresiva
total	parcial			
2.05	0.55	7 	toma Ruta 50	45.03
2.57	0.52	8 		44.51
3.20	0.63	9 		43.88
6.55	3.35	10 		40.53
7.79	1.24	11 	toma Ruta 29	39.29
23.46	15.67	12 		23.62







CH 0 - PQUE. ASISTENCIA SALIDA	Dist.Sector 47,08 km	Etapa: 1	Pag 16
CH 1 - EL CHINCHULIN		Sección: 1	
Prueba Especial	Dist. P.E. km	Promedio 62,77 km/h	Tiempo Otorgado 0:45

distancia		direccion	informacion	distancia regresiva
total	parcial			
24.82	1.36	13 		22.26
38.14	13.32	14 		8.94
43.95	5.81	15 	Puente sobre Arroyo El Perdido	3.13
44.30	0.35	16 	deja Ruta 29 Ingresa a Campo	2.78
44.34	0.04	17 		2.74
45.71	1.37	18 		1.37

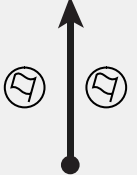

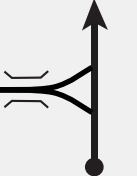

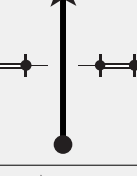

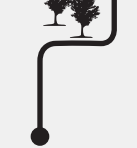

CH 0 - PQUE. ASISTENCIA SALIDA	Dist.Sector 47,08 km	Etapa: 1	Pag 17
CH 1 - EL CHINCHULIN		Sección: 1	
Prueba Especial	Dist. P.E. km	Promedio 62,77 km/h	Tiempo Otorgado 0:45

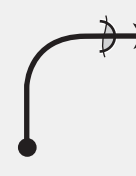
distancia		direccion	informacion	distancia regresiva
total	parcial			
46.59	0.88	19 		0.49
47.08	0.49	20 	CH 1 - El Chinchulin 	0.00

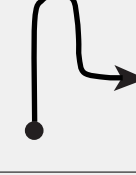
LPE 1 - EL CHINCHULIN		Dist.Sector	Etapa: 1	Pag
CH 2 - LOMA DE CEVERIO		31,13 km	Sección: 1	18
Prueba Especial		Dist. P.E.	Promedio	Tiempo Otorgado
1	EL CHINCHULIN	12,45 km	62,26 km/h	0:30

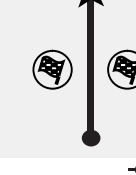
distancia		direccion	informacion	distancia regresiva
total	parcial			
0.00	0.00	1 	  S 36°49.255 O 58°34.756	31.13
3.15	3.15	2 		27.98
7.57	4.42	3 		23.56
9.40	1.83	4 		21.73
10.50	1.10	5 	por Camino Demarcado	20.63
11.10	0.60	6 		20.03

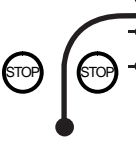

LPE 1 - EL CHINCHULIN		Dist.Sector	Etapa: 1	Pag
CH 2 - LOMA DE CEVERIO		31,13 km	Sección: 1	19
Prueba Especial		Dist. P.E.	Promedio	Tiempo Otorgado
1	EL CHINCHULIN	12,45 km	62,26 km/h	0:30

distancia		direccion	informacion	distancia regresiva
total	parcial			
11.38	0.28	7 		19.75
11.46	0.08	8 	 cruza Vado con Agua	19.67
11.54	0.08	9 		19.59
11.96	0.42	10 		19.17
12.06	0.10	11 	  S 36°52.687 O 58°38.533	19.07
12.23	0.17	12 	Entra a Campo y sigue por Camino Demarcado   S 36°52.753 O 58°38.451	18.90

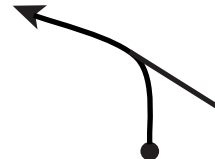
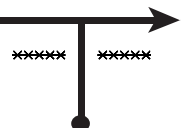
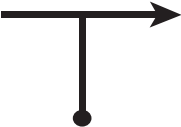
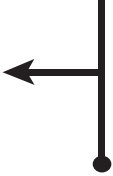
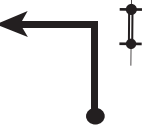
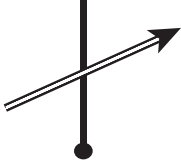

LPE 1 - EL CHINCHULIN		Dist.Sector	Etapa: 1	Pag
CH 2 - LOMA DE CEVERIO		31,13 km	Sección: 1	20
Prueba Especial	Dist. P.E.	Promedio	Tiempo Otorgado	
	km	62,26 km/h	0:30	

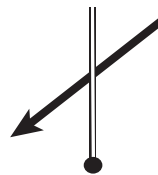
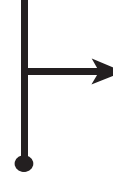
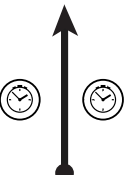
distancia		direccion	informacion	distancia regresiva
total	parcial			
14.30	2.07	13 		16.83
14.42	0.12	14 	Sale de Campo y sigue por Camino Real	16.71
16.95	2.53	15 		14.18
18.26	1.31	16 		12.87
26.56	8.30	17 		4.57
28.55	1.99	18 	toma Ruta 29	2.58

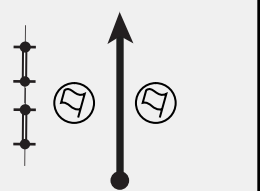

LPE 1 - EL CHINCHULIN		Dist.Sector	Etapa: 1	Pag
CH 2 - LOMA DE CEVERIO		31,13 km	Sección: 1	21
Prueba Especial	Dist. P.E.	Promedio	Tiempo Otorgado	
	km	62,26 km/h	0:30	

distancia		direccion	informacion	distancia regresiva
total	parcial			
29.90	1.35	19 	deja Ruta 29	1.23
30.53	0.63	20 		0.60
31.13	0.60	21 	 GH 1 - Loma de Ceverio  S 36°59.188 O 58°31.521	0.00

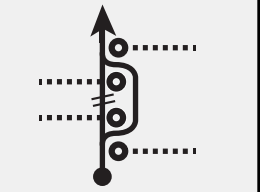
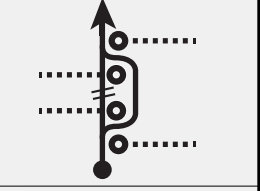
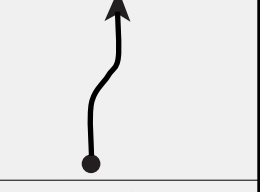
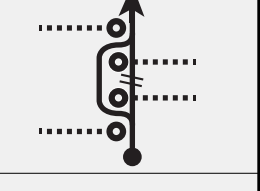
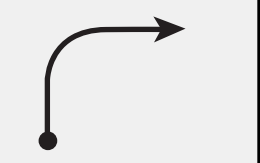

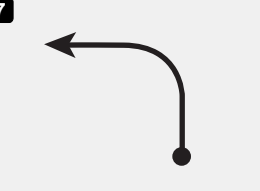
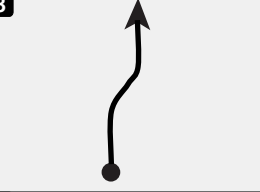
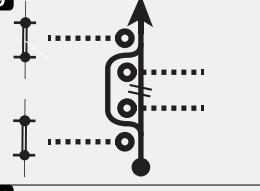
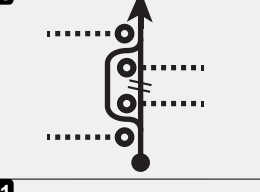
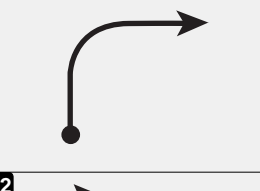

LPE	2 - LOMA DE CEVERIO	23,60	Etapa:	1	Pag 22
CH	3 - LA CAVA		Sección:	1	
Prueba Especial	2 LOMA DE CEVERIO	Dist. P.E. 13,80 km	Promedio 56,64 km/h	Tiempo Otorgado	0:25

distancia		direccion	informacion	distancia regresiva
total	parcial			
0.00	0.00	1 	LPE 2 - Loma de Ceverio  S 36°59.215 O 58°31.487	23.60
1.40	1.40	2 	! CHICANA SALE CAMINO ① VEEDOR	22.20
3.00	1.60	3 	! CHICANA SALE CAMINO ② VEEDOR	20.60
3.65	0.65	4 		19.95
4.25	0.60	5 	! CHICANA SALE CAMINO ③ VEEDOR	19.35
5.00	0.75	6 		18.60



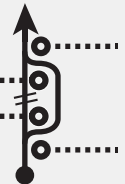

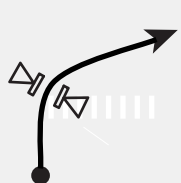

LPE	1 - LOMA DE CEVERIO	23,60 km	Etapa:	1	Pag 23
CH	3 - LA CAVA		Sección:	1	
Prueba Especial	2 LOMA DE CEVERIO	Dist. P.E. 13,80 km	Promedio 56,64 km/h	Tiempo Otorgado	0:25

distancia		direccion	informacion	distancia regresiva
total	parcial			
6.20	1.20	7 		17.40
6.85	0.65	8 		16.75
7.35	0.50	9 	! CHICANA SALE CAMINO ④ "La Carlota" VEEDOR	16.25
8.30	0.95	10 	! CHICANA SALE CAMINO ⑤ "La Carlota" VEEDOR	15.30
8.80	0.50	11 	! PELIGRO	14.80
9.55	0.75	12 		14.05

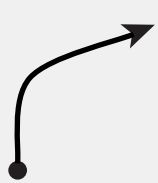
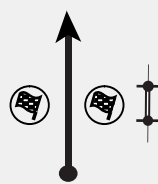

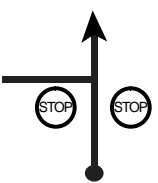
LPE	2 - LOMA DE CEVERIO	23,60	Etapa: 1	Pag
CH	3 - LA CAVA		Sección: 1	24
Prueba Especial	2 LOMA DE CEVERIO	Dist. P.E. 13,80 km	Promedio 56,64 km/h	Tiempo Otorgado 0:25

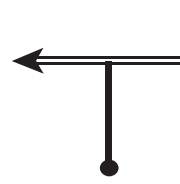
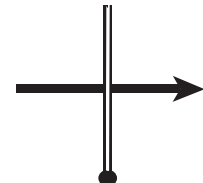
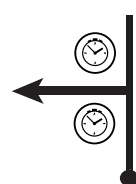
distancia		direccion	informacion	distancia regresiva
total	parcial			
9.95	0.40	13 	! PUENTE	13.65
10.60	0.65	14 	! CHICANA SALE CAMINO (6) VEEDOR	13.00
11.60	1.00	15 	! CHICANA SALE CAMINO (7) VEEDOR	12.00
12.30	0.70	16 	! CHICANA SALE CAMINO (8) VEEDOR	11.30
12.70	0.40	17 		10.90
13.25	0.55	18 		10.35

LPE	1 - LOMA DE CEVERIO	23,60 km	Etapa: 1	Pag
CH	2 - LA CAVA		Sección: 1	25
Prueba Especial	2 LOMA DE CEVERIO	Dist. P.E. 13,80 km	Promedio 56,64 km/h	Tiempo Otorgado 0:25

distancia		direccion	informacion	distancia regresiva
total	parcial			
13.65	0.40	19 		10.90
13.80	0.15	20 	FPE 2 - Loma de Ceverio  S 37°05.362 O 58°29.459	9.80
14.32	0.52	21 	STOP  S 37°05.577 O 58°29.695	9.28
20.10	5.78	22 	toma Ruta 50	3.50
23.45	3.35	23 	por Los Horneros	0.15
23.60	0.15	24 	CH 3 - La Cava  S 37°09.178 O 58°30.641	0.00

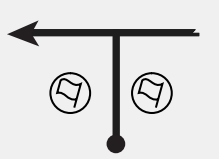
LPE 3 - LA CAVA		Dist.Sector	Etapa: 1	Pag
CH 3A - PQUE. ASISTENCIA INGRESO		11,80 km	Sección: 1	26
Prueba Especial	Dist. P.E.	Promedio	Tiempo Otorgado	
3 LA CAVA / C.A.I.	10,50 km	47,20 km/h	0:15	

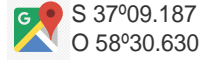
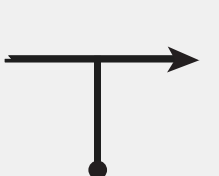
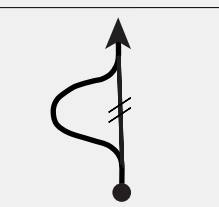
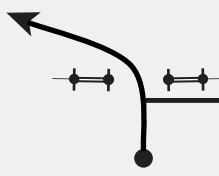
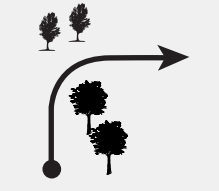
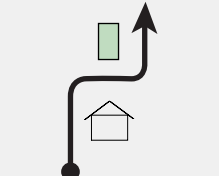
distancia		direccion	informacion	distancia regresiva
total	parcial			
0.00	0.00	1 	 	11.80
0.10	0.10	2 		11.70
0.22	0.12	3 		11.58
0.32	0.10	4 	por Porton	11.48
0.40	0.08	5 		11.40
0.55	0.15	6 		11.25

LPE 3 - LA CAVA		Dist.Sector	Etapa: 1	Pag
CH 3A - PQUE. ASISTENCIA INGRESO		11,80 km	Sección: 1	27
Prueba Especial	Dist. P.E.	Promedio	Tiempo Otorgado	
3 LA CAVA / C.A.I.	10,50 km	47,20 km/h	0:15	

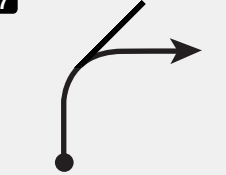
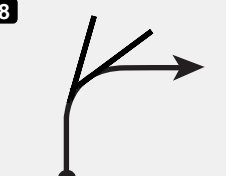
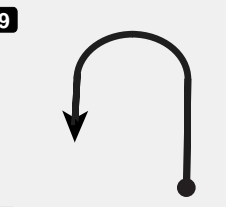
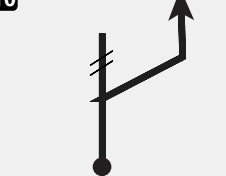
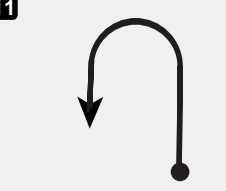
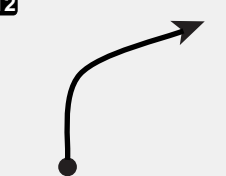
distancia		direccion	informacion	distancia regresiva
total	parcial			
0.83	0.28	7 	por camino demarcado	10.97
0.93	0.10	8 	por camino demarcado	10.87
1.09	0.16	9 	por camino demarcado	10.71
1.35	0.26	10 		10.45
1.50	0.15	11 		10.30
1.67	0.17	12 		10.13

LPE 3 - LA CAVA		Dist.Sector	Etapa: 1	Pag
CH 3A - PQUE. ASISTENCIA INGRESO		11,80 km	Sección: 1	28
Prueba Especial	3 LA CAVA / C.A.I.	Dist. P.E. 10,50 km	Promedio 47,20 km/h	Tiempo Otorgado 0:15

distancia		direccion	informacion	distancia regresiva
total	parcial			
1.80	0.13			10.00
1.92	0.12		por camino demarcado	9.88
2.08	0.16		por camino demarcado	9.72
2.17	0.09		por camino demarcado	9.63
2.23	0.06		sale de la Cava	9.57
2.49	0.26		ingresa al predio de Tiro Federal sigue camino demarcado	9.31

LPE 3 - LA CAVA		Dist.Sector	Etapa: 1	Pag
CH 3A - PQUE. ASISTENCIA INGRESO		11,80 km	Sección: 1	29
Prueba Especial	3 LA CAVA / C.A.I.	Dist. P.E. 10,50 km	Promedio 47,20 km/h	Tiempo Otorgado 0:15

distancia		direccion	informacion	distancia regresiva
total	parcial			
2.72	0.23			9.08
2.85	0.13			8.95
2.93	0.08			8.87
3.05	0.12			8.75
3.12	0.07		sale del predio de Tiro Federal	8.68
3.22	0.10			8.58



LPE 3 - LA CAVA		Dist.Sector	Etapa: 1	Pag
CH 3A - PQUE. ASISTENCIA INGRESO		11,80 km	Sección: 1	30
Prueba Especial		Dist. P.E.	Promedio	Tiempo Otorgado
3	LA CAVA / C.A.I.	10,50 km	47,20 km/h	0:15

distancia		direccion	informacion	distancia regresiva
total	parcial			
4.00	0.78			7.80
4.60	0.60		ingresa entre corrales	7.20
4.75	0.15			7.05
4.90	0.15			6.90
5.15	0.25			6.65
6.00	0.85			5.80

LPE 3 - LA CAVA		Dist.Sector	Etapa: 1	Pag
CH 3A - PQUE. ASISTENCIA INGRESO		11,80 km	Sección: 1	31
Prueba Especial		Dist. P.E.	Promedio	Tiempo Otorgado
3	LA CAVA / C.A.I.	10,50 km	47,20 km/h	0:15

distancia		direccion	informacion	distancia regresiva
total	parcial			
6.25	0.25		! CHICANA SALE CAMINO ①	5.55
6.40	0.15		VEEDOR * Largada Shakedown	5.40
6.55	0.15		ingresa al predio C.A.I. entre portones	5.25
6.65	0.10		* Largada Shakedown	5.15
6.85	0.20		por detras de Plantas sigue camino demarcado	4.95
6.95	0.10		entre Plantas sigue camino demarcado	4.85

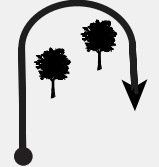
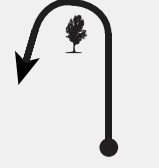
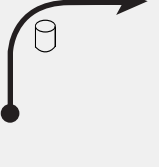
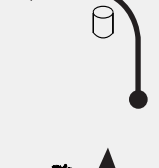

LPE 3 - LA CAVA		Dist.Sector	Etapa: 1	Pag
CH 3A - PQUE. ASISTENCIA INGRESO		11,80 km	Sección: 1	32
Prueba Especial	Dist. P.E.	Promedio	Tiempo Otorgado	
3 LA CAVA / C.A.I.	10,50 km	47,20 km/h	0:15	

distancia		direccion	informacion	distancia regresiva
total	parcial			
7.05	0.10		por detras de Plantas sigue camino demarcado	4.75
7.20	0.15		por detras de Planta sigue camino demarcado	4.60
7.25	0.05		por detras de Tubo sigue camino demarcado	4.55
7.35	0.10		por detras de Tubo sigue camino demarcado	4.45
7.38	0.03		entre Plantas sigue camino demarcado	4.42
7.40	0.02			4.40

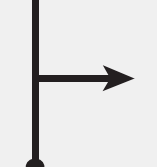
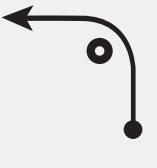
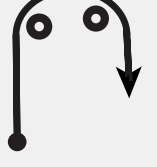
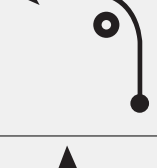
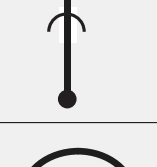
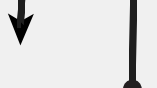

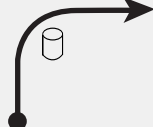
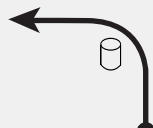
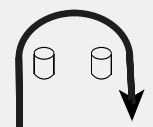
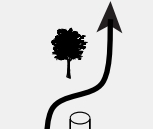
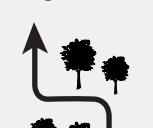

LPE 3 - LA CAVA		Dist.Sector	Etapa: 1	Pag
CH 3A - PQUE. ASISTENCIA INGRESO		11,80 km	Sección: 1	33
Prueba Especial	Dist. P.E.	Promedio	Tiempo Otorgado	
3 LA CAVA / C.A.I.	10,50 km	47,20 km/h	0:15	

distancia		direccion	informacion	distancia regresiva
total	parcial			
7.60	0.20			4.20
7.65	0.05		ingresa al predio C.A.I. entre portones	4.15
7.75	0.10			4.05
7.90	0.15			3.90
8.15	0.25		LOMO	3.65
8.40	0.25		por detras de Tubo sigue camino demarcado	3.40



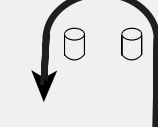
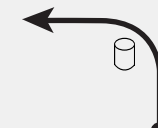
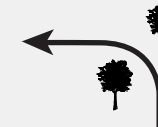
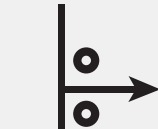

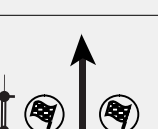
LPE 3 - LA CAVA		Dist.Sector	Etapa: 1	Pag
CH 3A - PQUE. ASISTENCIA INGRESO		11,80 km	Sección: 1	34
Prueba Especial	Dist. P.E.	Promedio	Tiempo Otorgado	
3 LA CAVA / C.A.I.	10,50 km	47,20 km/h	0:15	

distancia		direccion	informacion	distancia regresiva
total	parcial			
8.54	0.14	49 	por detras de Tubo sigue camino demarcado	3.26
8.60	0.06	50 	por detras de Tubo sigue camino demarcado	3.20
8.85	0.25	51 	por detras de Tubos sigue camino demarcado	2.95
9.15	0.30	52 	entre Tubo y Plantas sigue camino demarcado	2.65
9.25	0.10	53 	entre Plantas sigue camino demarcado	2.55
9.35	0.10	54 	entre Alambrado y Plantas sigue camino demarcado	2.45

LPE 3 - LA CAVA		Dist.Sector	Etapa: 1	Pag
CH 3A - PQUE. ASISTENCIA INGRESO		11,80 km	Sección: 1	35
Prueba Especial	Dist. P.E.	Promedio	Tiempo Otorgado	
3 LA CAVA / C.A.I.	10,50 km	47,20 km/h	0:15	

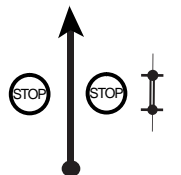
distancia		direccion	informacion	distancia regresiva
total	parcial			
9.50	0.15	55 	por detras de Tubos sigue camino demarcado	2.30
9.65	0.15	56 	por detras de Tubo sigue camino demarcado	2.15
9.70	0.05	57 	entre Plantas sigue camino demarcado	2.10
10.23	0.53	58 		1.57
10.30	0.07	59 	Sale a camino Real	1.50
10.50	0.20	60 	 3 - C.A.I.	1.30
		 S 37°09.716 O 58°30.226		

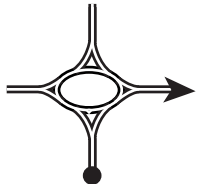
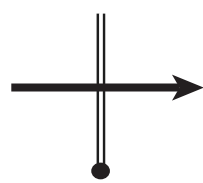
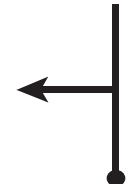
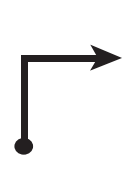
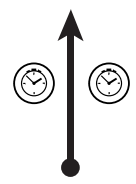
LPE 3 - LA CAVA		Dist.Sector	Etapa: 1	Pag
CH 3A - PQUE. ASISTENCIA INGRESO		11,80 km	Sección: 1	36
Prueba Especial	Dist. P.E.	Promedio 47,20 km/h	Tiempo Otorgado 0:15	

distancia		direccion	informacion	distancia regresiva
total	parcial			
10.88	0.38	61 	  S 37°09.562 O 58°30.053	0.92
10.92	0.04	62 	toma Ruta 50	0.88
11.20	0.28	63 	ingresa a C.A.I.	0.60
11.28	0.08	64 		0.52
11.40	0.12	65 		0.40
11.80	0.40	66 	 CH 3A - Pque. Asistencia Ing.  S 37°09.744 O 58°29.903	0.00

CH		Dist.Sector	Etapa:	Pag
CH		km	Sección:	37
Prueba Especial	Dist. P.E.	Promedio	Tiempo Otorgado	

Secciones 2 y 3: identicas a la Sección 1



CH 9E - PQUE. ASISTENCIA SALIDA	Dist.Sector 24,68 km	Etapa: 2	Pag 38
CH 10 - LOMA DE CEVERIO	Promedio 48,52 km/h	Sección: 4	
Prueba Especial	Dist. P.E. km	Tiempo Otorgado 0:30	

distancia		direccion	informacion	distancia regresiva
total	parcial			
0.00	0.00	1 	CH 0 - Pque. Asistencia Sal. S 37°09.832 O 58°29.859	24.68
0.28	0.28	2 	toma Ruta 50	24.40
0.59	0.31	3 		24.09
0.81	0.22	4 	por Avenida Miguens	23.87
1.44	0.63	5 	Reabastecimiento 	23.24
1.50	0.06	6 	por Avenida Miguens	23.18





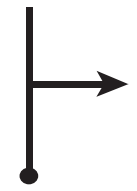
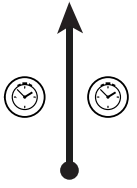

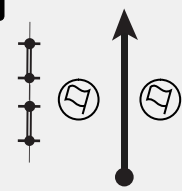

CH 9E - PQUE. ASISTENCIA SALIDA	Dist.Sector 24,68 km	Etapa: 2	Pag 39
CH 10 - LOMA DE CEVERIO	Promedio 48,52 km/h	Sección: 4	
Prueba Especial	Dist. P.E. km	Tiempo Otorgado 0:30	

distancia		direccion	informacion	distancia regresiva
total	parcial			
2.05	0.55	7 	toma Ruta 50	22.63
2.57	0.52	8 		22.11
3.20	0.63	9 		21.48
6.55	3.35	10 		18.13
7.79	1.24	11 	toma Ruta 29	16.89
23.46	15.67	12 		1.22



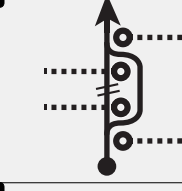

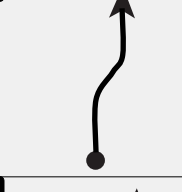
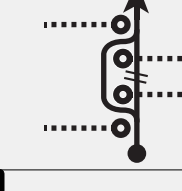
CH	9E - PQUE. ASISTENCIA SALIDA		Dist.Sector	Etapa: 2	Pag
CH	10 - LOMA DE CEVERIO		24,68 km	Sección: 4	40
Prueba Especial	Dist. P.E.	Promedio	Tiempo Otorgado		
	km	48,52 km/h	0:30		

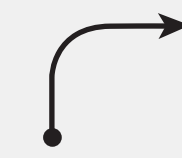
distancia		direccion	informacion	distancia regresiva
total	parcial			
24.10	0.64	19 		0.58
24.68	0.58	20 	 CH 10 - Loma de Ceverio  S 36°59.188 O 58°31.521	0.00



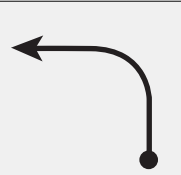

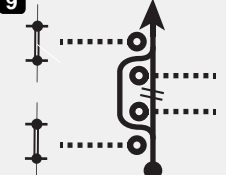
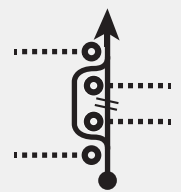
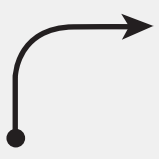
LPE	10 - LOMA DE CEVERIO		18,25	Etapa: 2	Pag
CH	11 - CHACRA MUNICIPAL			Sección: 4	41
Prueba Especial	Dist. P.E.	Promedio	Tiempo Otorgado		
10 LOMA DE CEVERIO	13,80 km	54,75 km/h	0:20		

distancia		direccion	informacion	distancia regresiva
total	parcial			
0.00	0.00	1 	 2 - Loma de Ceverio  S 36°59.215 O 58°31.487	18.25
1.40	1.40	2 	 CHICANA SALE CAMINO ① VEEDOR	16.85
3.00	1.60	3 	 CHICANA SALE CAMINO ② VEEDOR	15.25
3.65	0.65	4 		14.60
4.25	0.60	5 	 CHICANA SALE CAMINO ③ VEEDOR	14.00
5.00	0.75	6 		13.25





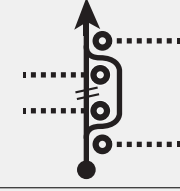
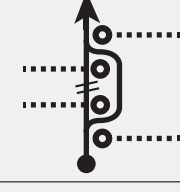
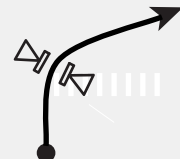

LPE	10 - LOMA DE CEVERIO	Dist.Sector	18,25 km	Etapa: 2	Pag 42		
CH	11 - CHACRA MUNICIPAL			Sección: 4			
Prueba Especial	10 LOMA DE CEVERIO	Dist. P.E.	13,80 km	Promedio	54,75 km/h	Tiempo Otorgado	0:20

distancia		direccion	informacion	distancia regresiva
total	parcial			
6.20	1.20			12.05
6.85	0.65			11.40
7.35	0.50		! CHICANA SALE CAMINO (4) "La Carlota" VEEDOR	10.90
8.30	0.95		! CHICANA SALE CAMINO (5) VEEDOR	9.95
8.80	0.50		! PELIGRO	9.45
9.55	0.75			8.70

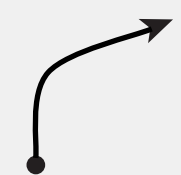
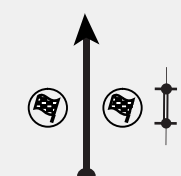

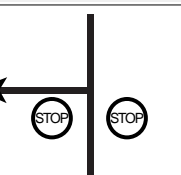

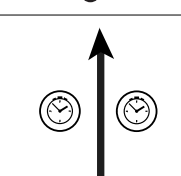

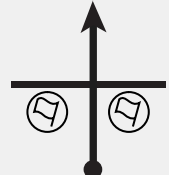

LPE	10 - LOMA DE CEVERIO	Dist.Sector	18,25 km	Etapa: 2	Pag 43		
CH	11 - CHACRA MUNICIPAL			Sección: 4			
Prueba Especial	10 LOMA DE CEVERIO	Dist. P.E.	13,80 km	Promedio	54,75 km/h	Tiempo Otorgado	0:20

distancia		direccion	informacion	distancia regresiva
total	parcial			
9.95	0.40		! PUENTE	8.30
10.60	0.65		! CHICANA SALE CAMINO (6) VEEDOR	7.65
11.60	1.00		! CHICANA SALE CAMINO (7) VEEDOR	6.65
12.30	0.70		! CHICANA SALE CAMINO (8) VEEDOR	5.95
12.70	0.40			5.55
13.25	0.55			5.00

LPE	10 - LOMA DE CEVERIO	Dist. Sector	18,25 km	Etapa:	2	Pag	44
CH	11 - CHACRA MUNICIPAL	Sección:	4				
Prueba Especial	10 LOMA DE CEVERIO	Dist. P.E.	13,80 km	Promedio	54,75 km/h	Tiempo Otorgado	0:20

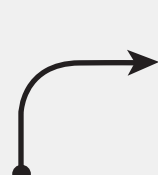
distancia		direccion	informacion	distancia regresiva
total	parcial			
13.65	0.40	19 		5.55
13.80	0.15	20 	FPE 2 - Loma de Ceverio  S 37°05.362 O 58°29.459	4.45
14.32	0.52	21 	  S 37°05.577 O 58°29.695	3.93
18.25	3.93	22 	CH 11 - Chacra Municipal  S 37°06.953 O 58°27.740	0.00

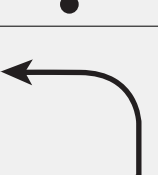

LPE	11 - CHACRA MUNICIPAL	Dist. Sector	15,02	Etapa:	2	Pag	45
CH	12 - LA CAVA	Sección:	4				
Prueba Especial	11 CHACRA MUNICIPAL	Dist. P.E.	8,12 km	Promedio	45,06 km/h	Tiempo Otorgado	0:20

distancia		direccion	informacion	distancia regresiva
total	parcial			
0.00	0.00	1 	 LPE 11 - Chacra Municipal  S 37°06.978 O 58°27.709	15.02
0.40	0.40	2 	! PUENTE	14.62
0.50	0.10	3 		14.52
0.80	0.30	4 	VADO	14.22
1.35	0.55	5 		13.67
1.70	0.35	6 	VADO	13.32

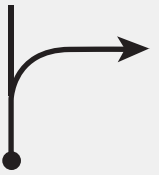
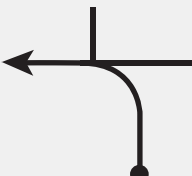
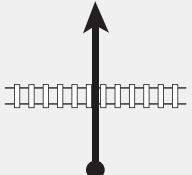
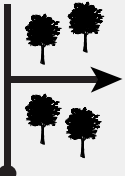
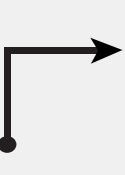
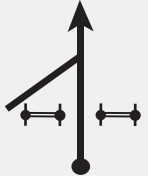

LPE	11 - CHACRA MUNICIPAL	15,02	Etapa: 2	Pag
CH	12 - LA CAVA		Sección: 4	46
Prueba Especial	11 CHACRA MUNICIPAL	Dist. P.E.	Promedio	Tiempo Otorgado
		8,12 km	45,06 km/h	0:20

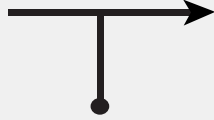
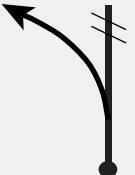
distancia		direccion	informacion	distancia regresiva
total	parcial			
1.90	0.20	7 		13.12
2.75	0.85	8 		12.27
3.30	0.55	9 	VIAS	11.72
3.65	0.35	10 	entre Plantas sigue camino demarcado	11.37
3.75	0.10	11 		11.27
4.00	0.25	12 		11.02

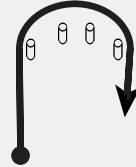
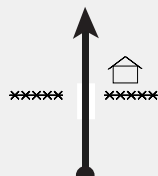

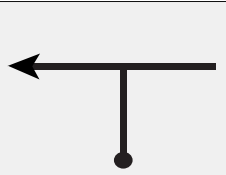
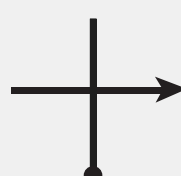
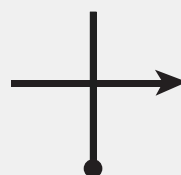
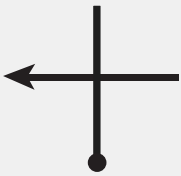
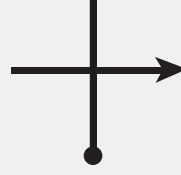
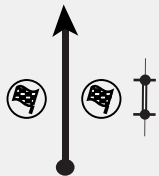

LPE	11 - CHACRA MUNICIPAL	15,02	Etapa: 2	Pag
CH	12 - LA CAVA		Sección: 4	47
Prueba Especial	11 CHACRA MUNICIPAL	Dist. P.E.	Promedio	Tiempo Otorgado
		8,12 km	45,06 km/h	0:20

distancia		direccion	informacion	distancia regresiva
total	parcial			
4.40	0.40	13 		10.62
4.80	0.40	14 		10.22
4.86	0.06	15 		10.16
4.96	0.10	16 		10.06
5.15	0.19	17 		9.87
5.37	0.22	18 		9.65

LPE	11 - CHACRA MUNICIPAL	15,02	Etapa: 2	Pag
CH	12 - LA CAVA		Sección: 4	48
Prueba Especial	11 CHACRA MUNICIPAL	Dist. P.E. 8,12 km	Promedio 45,06 km/h	Tiempo Otorgado 0:20

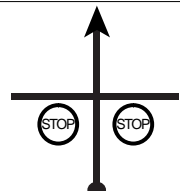
distancia		direccion	informacion	distancia regresiva
total	parcial			
5.50	0.13			9.52
5.70	0.20			9.32
6.25	0.55			8.77
7.10	0.85			7.92
7.65	0.55			7.37
8.12	0.47		 11 - Chacra Municipal  S 37°09.368 O 58°27.331	6.90

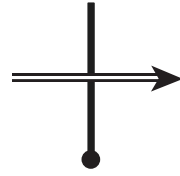
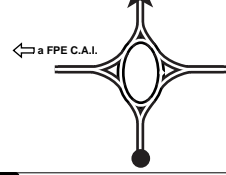
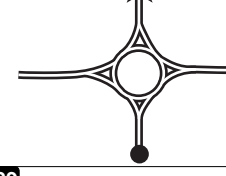
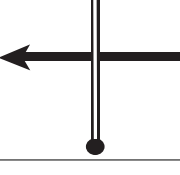
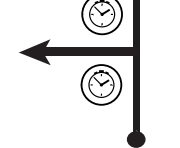
LPE	11 - CHACRA MUNICIPAL	15,02	Etapa: 2	Pag
CH	12 - LA CAVA		Sección: 4	49
Prueba Especial	11 CHACRA MUNICIPAL	Dist. P.E. 8,12 km	Promedio 45,06 km/h	Tiempo Otorgado 0:20

distancia		direccion	informacion	distancia regresiva
total	parcial			
8.47	0.35		  S 37°09.516 O 58°27.490	6.55
10.95	2.48		toma Ruta 50	4.07
13.67	2.72			1.35
14.22	0.55			0.80
14.88	0.66		por Los Horneros	0.14
15.02	0.14		 12 - La Cava  S 37°09.178 O 58°30.641	0.00

CH		Dist. Sector	Etapa:	Pag 50
CH		km	Sección:	
Prueba Especial	Dist. P.E.	Promedio	Tiempo Otorgado	
	km	km/h		

PE12 / 15 LA CAVA / C.A.I.: Idem a PE3 / 6 / 9

Repetir Paginas 26 a 36

Sección 5 identica a Sección 4

OK

**MOSTRAR A LA PRÓXIMA TRIPULACIÓN EN CASO DE
NO NECESITAR ASISTENCIA MEDICA**

SOS

**MOSTRAR A LA PRÓXIMA TRIPULACIÓN EN CASO DE
NECESITAR ASISTENCIA MEDICA**